

 Needs to be **provided by promoter**/presenter/venue.

 Will be brought and **provided by artist**.

update: October 7th, 2018

4 full-range loudspeaker systems with 4 (or minimum 2) subwoofers placed in a square quad-position (see page 5 „AUDIO CONNECTIONS“).
all 4 speakers same distance to centre performing position.
the speaker distance to the centre should be as far as possible to ensure, that the audience, which is in circles around centre performing position, has still a good distance to the speakers to be able to perceive as much as possible quadrophonic sound projection.

8 short XLR-cables plus **stagebox/multicore**
connecting to the quad PA mixing console

– or –

8 long XLR-cables
connecting directly from audio-interfaces on stage to the quad PA mixing console

1 power socket with min. 3 plugs

2 piano benches (with adjustable height)

1 small mixing desk

preferred: Mackie 802VLZ or Mackie 1202VLZ, <http://tinyurl.com/htg2mun>

Needs to be placed on stage next to performing position

(see page 4 „STAGE POSITIONS“).

tables/boxes/case for setting up the analogue synthesizer according to SETUP OPTION 1, 2 or 3 **indicated on page 2** „SYNTH SETUP OPTIONS“

1 small table (or box, case, stool)

50-60 cm high, 30 cm long, 30 cm wide (19-24 in high, 12 in long, 12 in wide)

To place the small mixer/Mackie 802 on.

dimmed white light from ceiling (or stand/clip lamp or similar for synth)

needs to point onto synth panel with creating shadows.

contacts:

Thomas Lehn
+49 157 0337 1510
mail@thomaslehn.de
www.thomaslehn.de

Marcus Schmickler
+49 175 413 66 49
schmickler@a-musik.com
www.piethopraxis.org

 Needs to be **provided by promoter**/presenter/venue.

 Will be brought and **provided by artist**.

2 laptop computers (MacBook Pro)

2 audio interfaces

RME Fireface 400, <https://tinyurl.com/y7rejxss>

MOTU UltraLite-mk3 Hybrid, <http://tinyurl.com/zj6bf6w>

4 TRS - XLR male adaptor wires (15 cm)

connecting the MOTU audio interface to Quad PA mixer/multicore stage box

4 TRS - XLR male adaptor wires (ca. 60 cm)

connecting the RME audio interface to Quad PA mixer/multicore stage box

1 analogue synthesizer

modell: EMS Synthi AKS (including EMS KS touch-keyboard)

<https://tinyurl.com/y77cmmky>

1 MIDI controller

modell: Faderfox LV3, <https://tinyurl.com/ydgcwl6n>

1 stereo volume pedal

modell: Boss FV-50L, <https://tinyurl.com/y862os9e>

4 TS wires (unbalanced quarter inch jack cables)

connecting: synth > volume pedal > mixer

2 TRS - TRS wires (balanced quarter inch jack cables)

connecting: mixer > audio interface

2 USB cables

connecting: computer > audio interface, and computer > MIDI controller

1 piece of wood to put synth in angled position

Lehn/Schmickler | TECH RIDER - QUAD

QUADROPHONIC SETUP

(audio connections and positions)

Needs to be **provided by promoter/presenter/venue.**

Will be brought and **provided by artist.**

As TRS-XLR adapter cables are short, make connections to Quad PA
 - either via **8 short XLR** to stagebox/multicore,
 - or via **8 long XLR** from stage to Quad PA mixing console

routing	stagebox / console	>	speaker / sub
Ch. 1	>	>	1
Ch. 2	>	>	2
Ch. 3	>	>	3
Ch. 4	>	>	4

routing	stagebox / console	>	speaker / sub
Ch. 5	>	>	1
Ch. 6	>	>	2
Ch. 7	>	>	3
Ch. 8	>	>	4

stagebox / PA-console

Input Channels 1 - 4

Input Channels 5 - 8

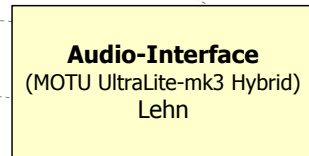
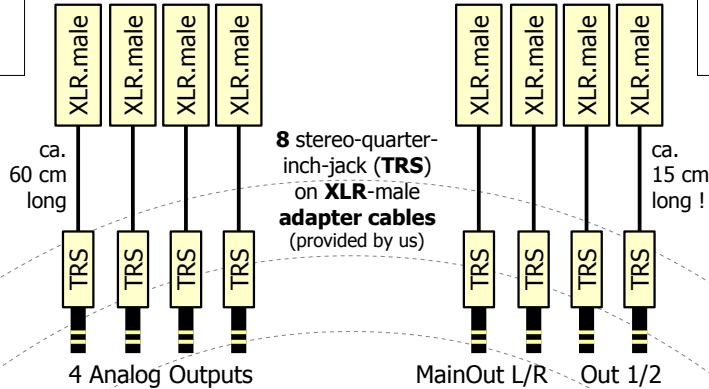

RME Fireface 400
 photo: <https://tinyurl.com/y7rejxss>

MOTU UltraLite-mk3
 photo: <http://tinyurl.com/zj6bf6w>

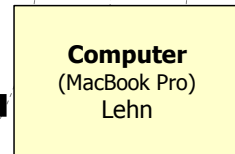
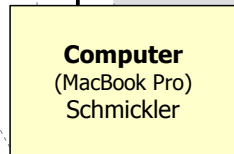

Mackie 802 VLZ3
 photo: <http://tinyurl.com/htg2mun>

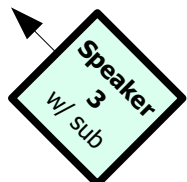
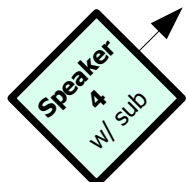
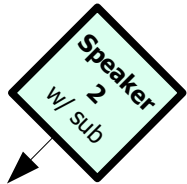
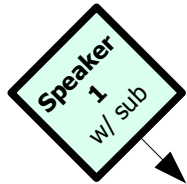
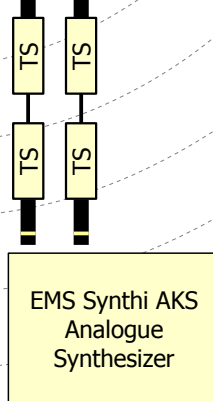

audience

audience

audience

grey:
stage
area
(centre)

Needs to be **provided by promoter/presenter/venue.**

Will be brought and **provided by artist.**

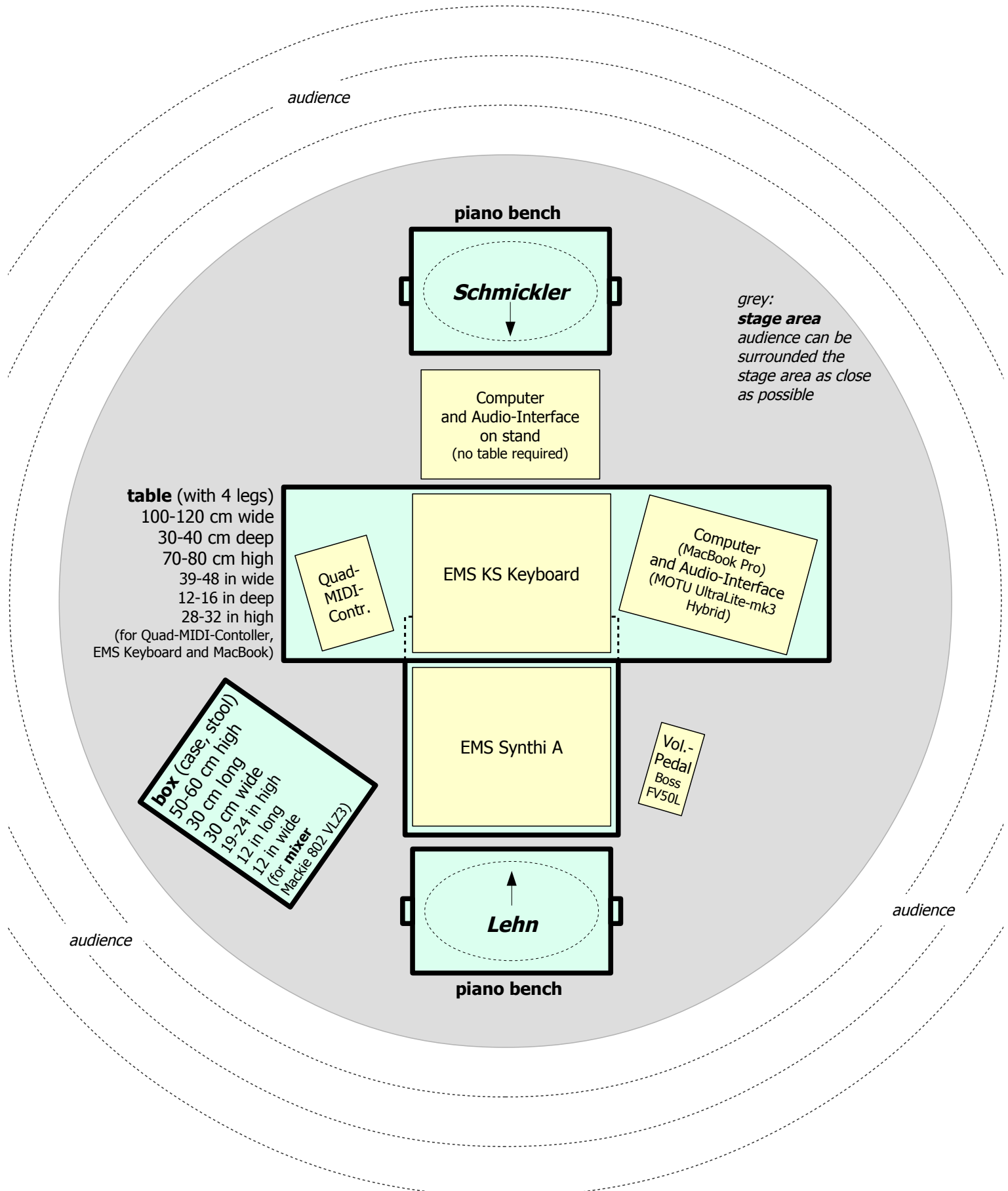

- Needs to be **provided by promoter/presenter/venue.**
- Will be brought and **provided by artist.**

Black cloth to cover boxes and tables.
 All 3 Setup Options require a small **box** (case, stool)
 H / W / L: 50-60 / 30 / 30 cm (19-24 / 12 / 12 in)
 (for mixer Mackie 802 VLZ3)

Setup Option 1

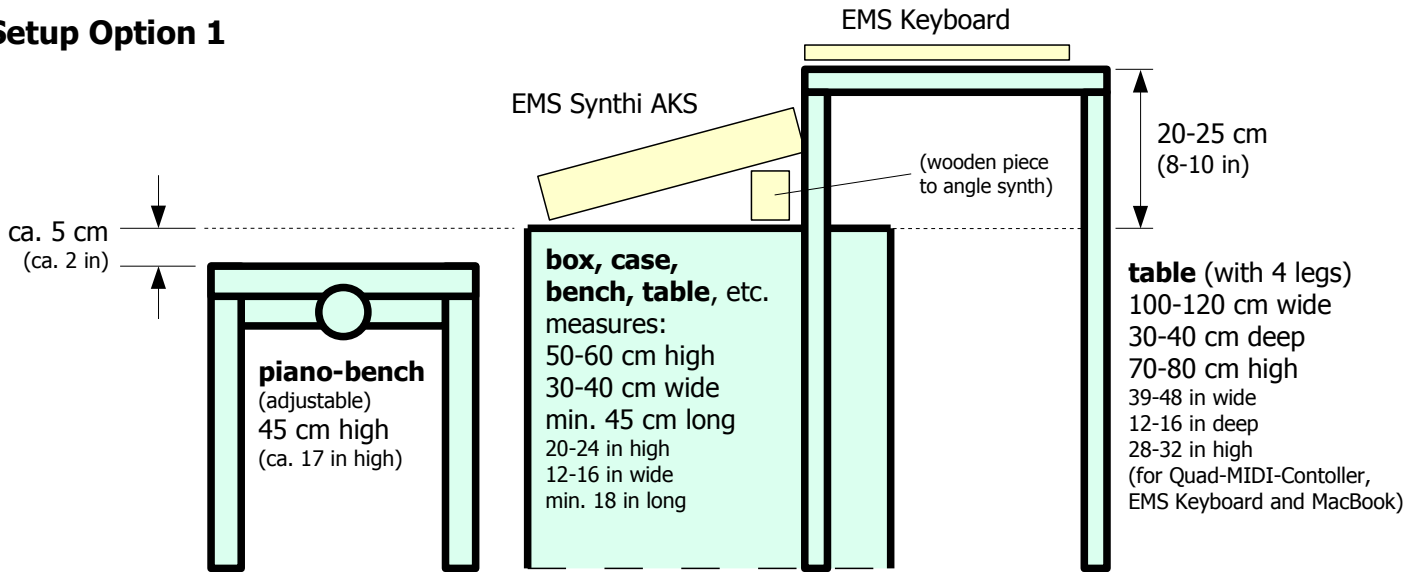

Setup Option 2

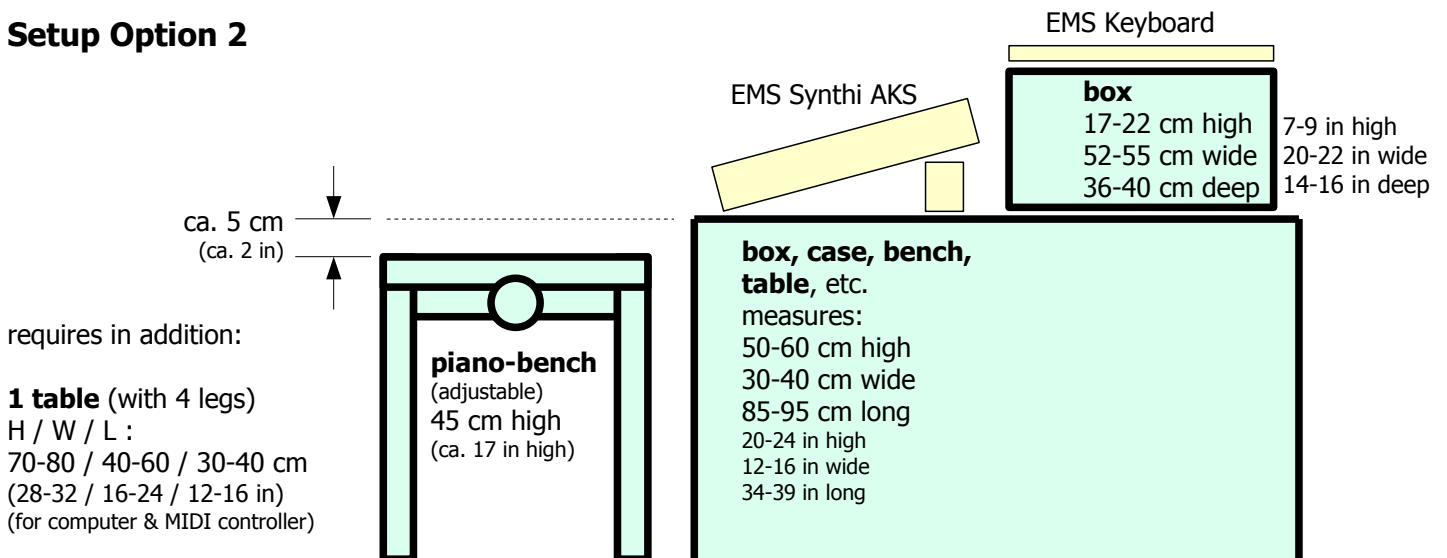

Setup Option 3

